

Florence-Darlington Technical College Technical Mathematics Contest Sample Problems

Problem Set 2

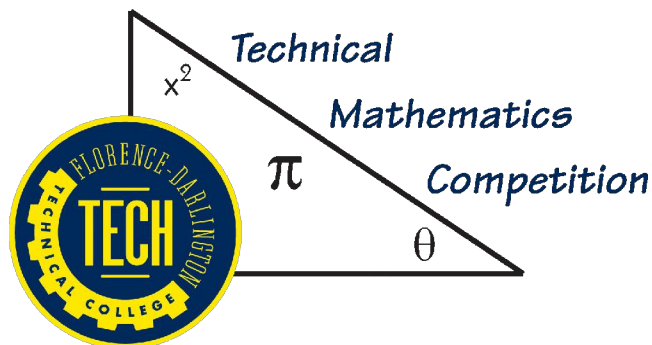

Mathematics Department
Florence-Darlington Technical College
P. O Box 100548
Florence SC 29501
Math@fdtc.edu

Enclosed are suggested problems for review for participation in the 2006 math contest. The problems are similar to problems used in previous contests. All problems use concepts and skills from arithmetic, geometry, algebra, and trigonometry. Students will be allowed to use calculators on all problems. Florence-Darlington Technical College requires either a TI-83 or TI-84 series calculator for all mathematics courses.

(All answers must include correct units and where necessary be rounded as requested. All problems should be completed by rounding only the final answer.)

21. The picture below shows a section of Interstate 90 through the state of Old Jersey. Exit numbers are given for each city, and these numbers indicate the distance from the western border of the state. A map is to be made of the interstate with a scale of $\frac{1}{2}$ inch = 20 miles. On the map, how many inches will Peachville be from Baxter? (Write your answer as a mixed number with reduced fraction.) - *Suggested Time Limit: 3 minutes*

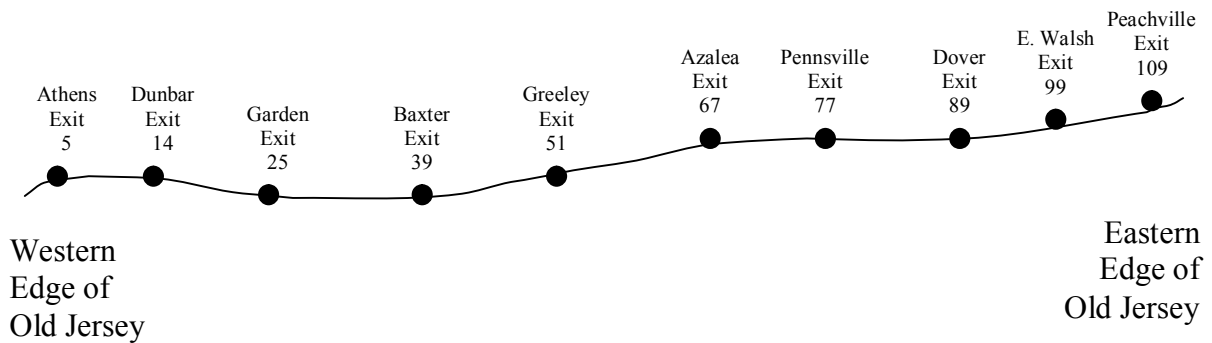

Distance between Peachville and Baxter: $d = 109 - 39 = 70$ mi.

Length on map: $l = 70 \text{ mi.} \times \frac{\frac{1}{2} \text{ in.}}{20 \text{ mi.}} = 1\frac{3}{4} \text{ in.}$

22. Florencia Fruit Juice comes in cans with a diameter of 3 inches. Labels are to be put on the cans with a $\frac{1}{2}$ inch overlap. The labels are printed on a roll that is 100 feet long and there is no waste between the labels. The labeling machine cuts one label off the roll at a time and glues it on a can. How many usable labels are there on the 100 foot roll? - *Suggested Time Limit: 3 minutes*

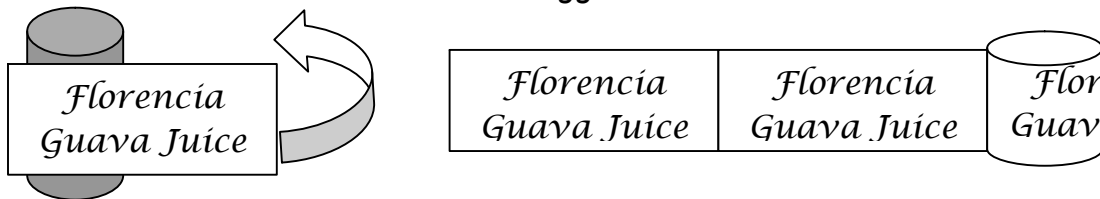

Length of each label: $l = C + 0.5 = \pi d + 0.5 = \pi(3) + 0.5 = (3\pi + 0.5) \text{ in.}$

The number of labels per roll is equal to the greatest integer less than

$$\frac{100 \text{ ft.}}{(3\pi + 0.5) \text{ in.}}$$

$$\frac{100 \text{ ft./roll}}{(3\pi + 0.5) \text{ in./label}} = \frac{100 \text{ ft./roll} \times \frac{12 \text{ in.}}{1 \text{ ft.}}}{(3\pi + 0.5) \text{ in./label}} = 120.91 \text{ labels/roll} = 120 \text{ labels/roll}$$

23. To measure the height of a hill, a string is drawn tight from level ground to the top of the hill. A yardstick is placed under the string, touching it at point P, at a distance of 5 feet from point G, where the string touches the ground. The string is then detached and found to be 120 feet long. How high is the hill in feet to the nearer foot? - *Suggested Time Limit: 5 minutes*

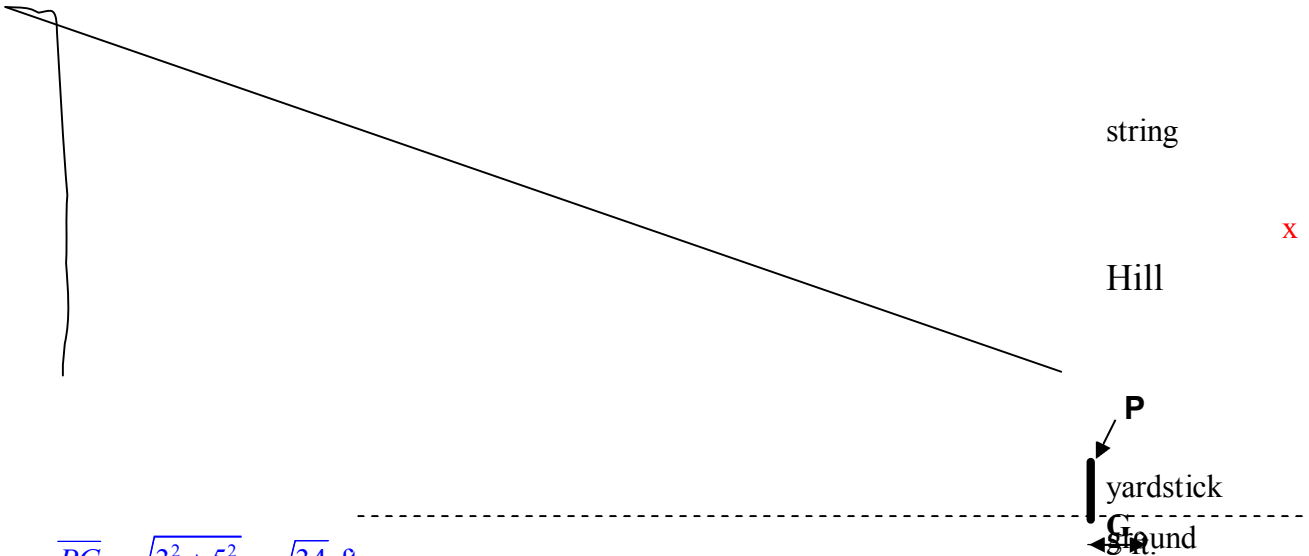

$$mPG = \sqrt{3^2 + 5^2} = \sqrt{34} \text{ ft.}$$

Solve for x using a proportion.

$$\frac{\text{hill}}{\text{yardstick}} = \frac{\text{string}}{mPG}$$

$$\frac{x \text{ ft.}}{3 \text{ ft.}} = \frac{120 \text{ ft.}}{\sqrt{34} \text{ ft.}}$$

$$x = 61.7 \text{ ft.}$$

24. The figure below shows a cylindrical sleeve made of steel with a density of 0.008 g/mm^3 . Find the mass in kilograms of one sleeve to the nearest 10^{th} kg. -
Suggested Time Limit: 5 minutes

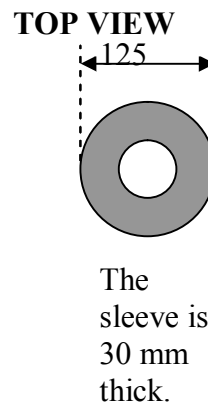
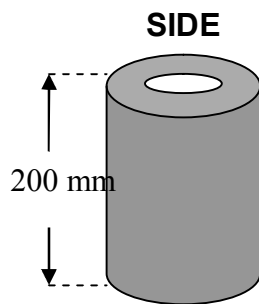

$$\text{density} = \frac{\text{mass}}{\text{volume}}$$

$$\text{mass} = \text{density} \times \text{volume} \text{ or } (m = dV)$$

$$m = 0.008 \text{ g/mm}^3 \times \left[\pi \left(\frac{125}{2} \text{ mm} \right)^2 (200 \text{ mm}) - \pi \left(\frac{65}{2} \text{ mm} \right)^2 (200 \text{ mm}) \right]$$

$$m = 14,325.7 \text{ g}$$

$$m = 14,325.7 \text{ g} \times \frac{1 \text{ kg}}{1000 \text{ g}} = 14.3 \text{ kg}$$

25. Find the area of the polygon below. (Not drawn to scale.) Give your answer to the nearest square inch. - *Suggested Time Limit: 3 minutes*

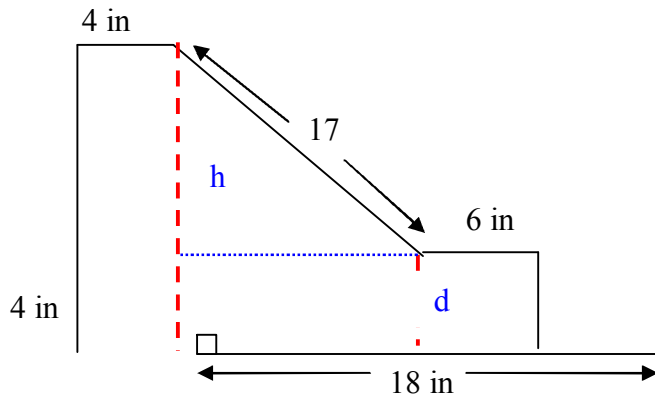

First find lengths d and h .

$$d = 18 - (4 + 6) \text{ in.} = 8 \text{ in.}$$

$$h = \sqrt{17^2 - 8^2} \text{ in.} = 15 \text{ in.}$$

Use any combination of areas of simple geometric figures to find total area, such as the two rectangles on the outside and the trapezoid in the middle.

$$A = (4 \times 19) \text{ in.}^2 + \left[\frac{(19 + 4)8}{2} \right] \text{ in.}^2 + (6 \times 4) \text{ in.}^2 = 192 \text{ in.}^2$$

26. Find the height of the flagpole in the figure below. The guy wire is 50 ft. long.
- *Suggested Time Limit: 3 minutes*

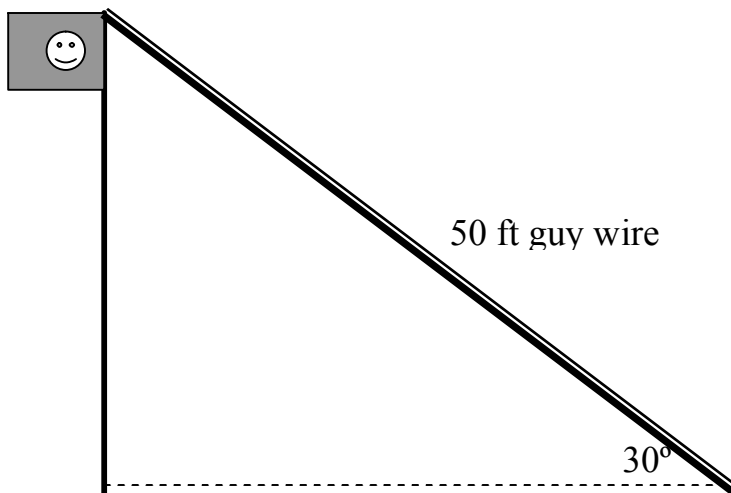

This is a $30^\circ - 60^\circ$ right triangle. The side opposite the 30 degree angle is equal to $\frac{1}{2}$ the length of the hypotenuse. Thus the height of the flagpole is **25 ft.**

27. At MacRobert's Restaurant, drinks come in two sizes, small and large. The drinks to fill the cups cost 5 cents per ounce. The restaurant pays 8 cents for a small cup and 10 cents for a large cup. The following table gives further information about the drinks. On which size drink does MacRobert's make the most profit? How much more profit does it make?

Cup Size	Ounces/cup	Customer price	Profit?
Small	10	\$0.95	
Large	14	\$1.15	

- Suggested Time Limit: 3 minutes

$$C_{small} = 0.08 + 0.05(10) = \$0.58$$

$$P_{small} = 0.95 - 0.58 = \$0.37$$

$$C_{large} = 0.10 + 0.05(14) = \$0.80$$

$$P_{large} = 1.15 - 0.80 = \$0.35$$

Sale of small cups produces \$0.02 more profit per cup.

28. The Lotsamoney Bank has decided to build a sidewalk around two sides of their bank building, as shown in the figure below. The sidewalk is to be 6 in. deep and the price of concrete is \$82.50 per cubic yard. What is the total cost (to the nearest dollar) of the concrete for the sidewalk? - Suggested Time Limit: 5 minutes

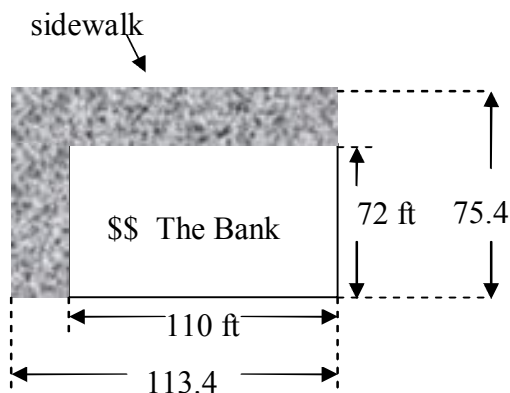

Area of shaded region: $A = [(113.4 \times 75.4) - (110 \times 72)] \text{ ft.}^2 = 630.36 \text{ ft.}^2$

Volume of sidewalk: $V = 630.36 \text{ ft.}^2 \times 0.5 \text{ ft.} \times \frac{1 \text{ yd.}^3}{27 \text{ ft.}^3} = 11.67\bar{3} \text{ yd.}$

Cost: $C = 11.67\bar{3} \text{ yd.} \times \frac{\$82.50}{1 \text{ yd.}} = \963

29. Hardwood flooring costs \$14.50 per square meter. What is the total cost of the hardwood flooring for the roller rink shown below? Assume 10% waste. (Use the pi key on the calculator. Round to nearest dollar. - *Suggested Time Limit: 3 minutes*)

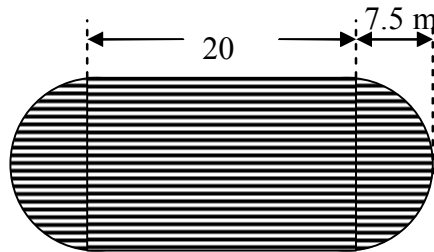

$$A = (20 \times 15) \text{ m} \times (\pi \cdot 7.5^2) \text{ m} = 476.7145868 \text{ m}^2$$

Allowing for 10% waste.

$$A = 476.7145868 \text{ m}^2 \times 1.1 = 524.3860454 \text{ m}^2$$

$$\text{Cost} = 524.3860454 \text{ m}^2 \times \frac{\$14.50}{1 \text{ m}^2} = \$7,604$$

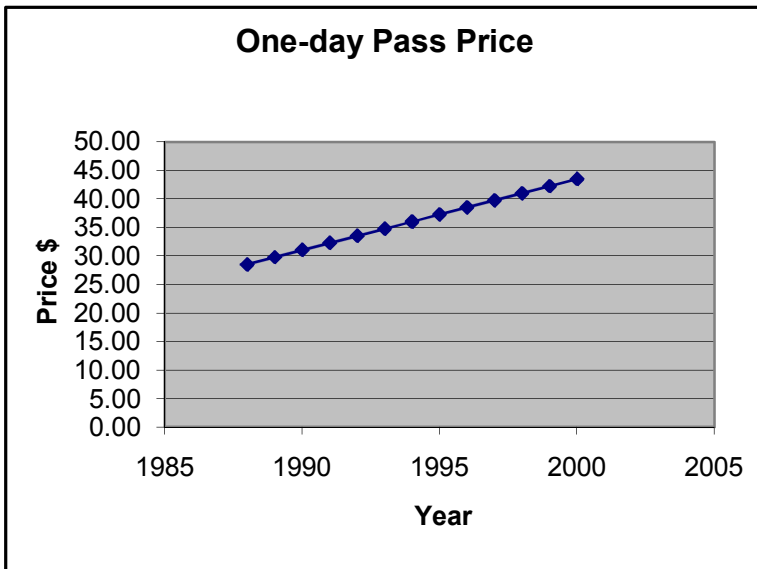

Year	Price
1988	28.50
1989	29.75
1990	31.00
1991	32.25
1992	33.50
1993	34.75
1994	36.00
1995	37.25
1996	38.50
1997	39.75
1998	41.00
1999	42.25
2000	43.50

30. The table and graph give the adult one-day pass price for Florence Adventure Land for the past several summers. Use the graph and the table to answer the following questions.

_____ a.) By how much did the price of a one-day ticket increase each year?

_____ b.) What would you expect this summer's (2001) price to be?

_____ c.) If the prices continue to increase each year by the same amount as above, in what year will the price be \$54.75?

- Suggested Time Limit: 5 minutes

a. The price increases at the rate of \$1.25 per year.

b. The 2001 price should be \$1.25 more than 2000. The 2001 price should be \$44.75.

c. Let $n=0$ represent the year 1988. The price could then be calculated using the following: $p = 1.25n + 28.50$. Solve for n when $p = \$54.75$.

$$1.25n + 28.50 = 54.75$$

$$1.25n = 26.25$$

$$n = 21$$

The year when the price will be \$54.75 is $1988 + 21 = 2009$

°A	°B
0	-5
10	27
20	59
30	91
40	123

31. The table to the left gives a comparison between temperature measurements on the Annashelski (°A) and the Bethius (°B) scales. For example, 10 °A is equivalent to 27 °B. Find a linear equation that gives °B as a function of °A. Use your model to find the equivalent °B for 48°A.

- Suggested Time Limit: 5 minutes

Graph the data points using °A for the independent variable and °B for the dependent variable. Note, the points are collinear. Select any two points and find the equation of the line passing through the two points. You may also use the “linear regression” program from your graphing calculator.

The equation is: $^{\circ}B = 3.2(^{\circ}A) - 5$, If $^{\circ}A = 48^{\circ}$, then $^{\circ}B = 3.2(48^{\circ}) - 5 = 148.6^{\circ}$

32. At Dewett Bacquards, the temperature on the widget solution tank is measured every hour. The target value for the widget solution temperature is 80°C. A tolerance of ±3°C is allowed. The following control chart shows the temperature readings for the last 24 hours. What percent (to the nearest tenth of a percent) of the readings were out of limits?

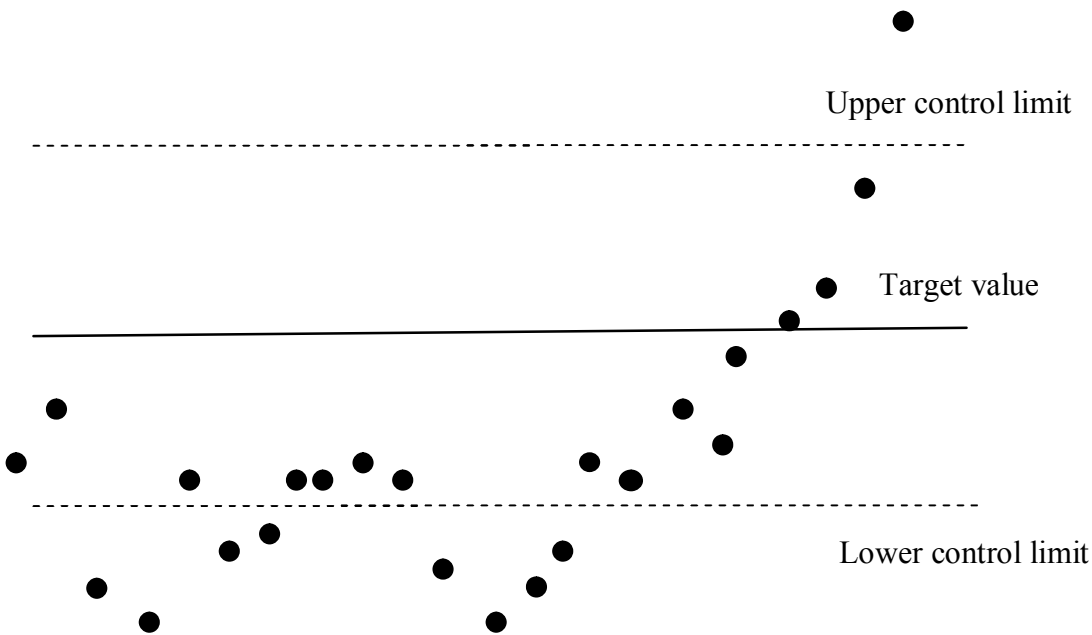



1	2	3	4	5	6	7	8	9	10	11	12	1	2	3	4	5	6	7	8	9	10	11	12
AM												PM											

- Suggested Time Limit: 5 minutes

$$\% \text{ Out of Control} = \frac{\# \text{ above upper limit} + \# \text{ below lower limit}}{\text{total \#}} \times 100\%$$

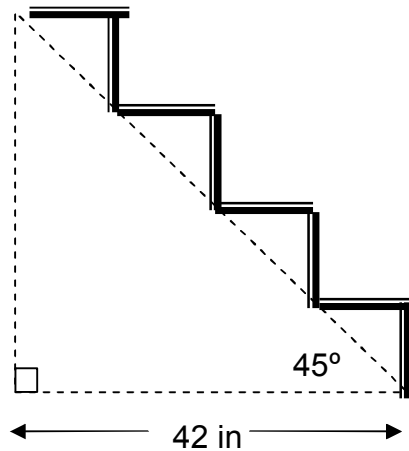
$$\% \text{ Out of Control} = \frac{1+8}{24} \times 100\% = 37.5\%$$



33. In the figure to the left,  shows where carpet will be placed on the steps. A piece of carpet with the correct width was found. To the nearest inch, how long should the carpet be?
 – Suggested Time Limit: 3 minutes

Total length of carpet needed is equal to the sum of the horizontal segments (42 in.) plus the sum of the vertical segments (42 in.) The total is 84 in.

34. Use the figure to the right to complete the following proportion between the large and small right triangles:

$$\frac{x}{z} = ?$$

- Suggested Time Limit: 3 minutes

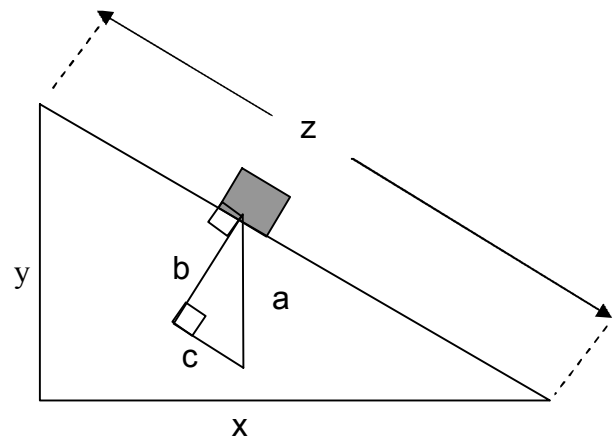

If a proportion may be written, then the two triangles are similar. Side x corresponds to side b and side z to a. The right side of the proportion is $\frac{b}{a}$.

35. Find x to the nearest thousandth of a meter.

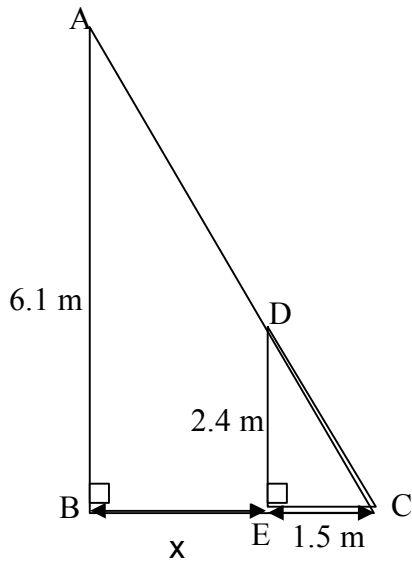

- Suggested Time Limit: 3 minutes

Since $\triangle ABC$ is similar to $\triangle DEC$, set up the following proportion and solve for x .

$$\frac{(x+1.5) \text{ m}}{1.5 \text{ m}} = \frac{6.1 \text{ m}}{2.4 \text{ m}}$$

$$2.4(x+1.5) = (1.5)(6.1)$$

$$2.4x + 3.6 = 9.15$$

$$2.4x = 5.55$$

$$x = 2.313 \text{ m}$$

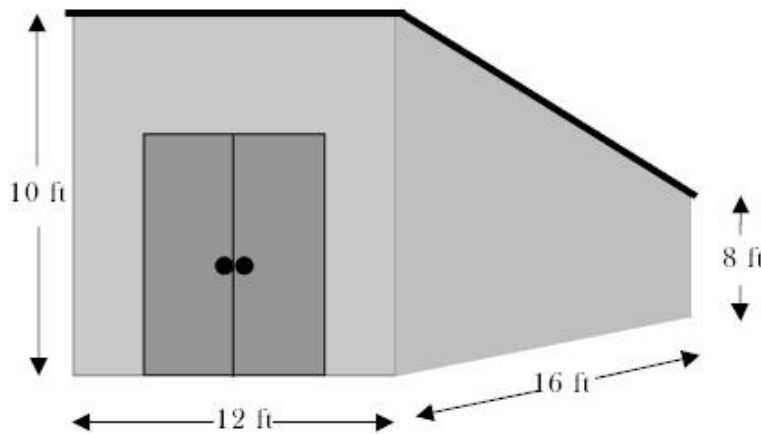

36. The figure to the left shows a storage shed with a slanted roof. There are no windows in the shed. The outside walls and doors of the shed need to be painted. One gallon of paint covers 230 square feet. Only full cans can be purchased. The paint cost is \$18.95 per gallon. The sales tax

rate is 6%. How much will the paint cost for the shed?

- Suggested Time Limit: 5 minutes

(1) Find the total lateral surface area (including doors) of the shed.

$$A = (12 \times 10) \text{ ft.}^2 + \frac{(10+8)16}{2} \text{ ft.}^2 + (12 \times 8) \text{ ft.}^2 + \frac{(10+8)16}{2} \text{ ft.}^2 = 504 \text{ ft.}^2$$

(2) Find the number of gallon cans of paint needed.

$$\text{No. gallon cans} = \frac{504 \text{ ft.}^2}{230 \text{ ft.}^2/\text{gal.}} = 2.2 \text{ gal.} = 3 \text{ gal.}$$

(3) Find cost.

$$\text{Cost} = 3 \text{ gal.} \times \frac{\$18.95}{1 \text{ gal.}} \times 1.06 = \$60.26$$

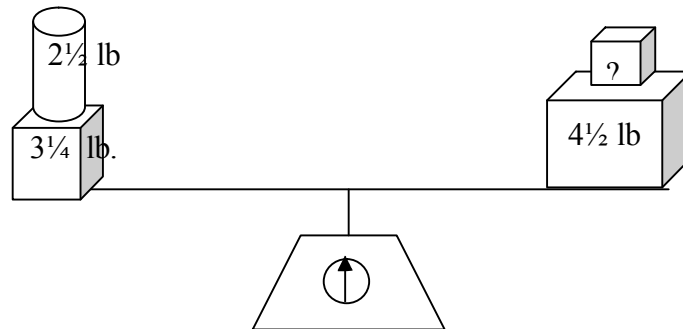

37. The containers are balanced correctly on the scales above. What is the weight of the container with the question mark? Write your answer as a mixed number or proper fraction in reduced form. *-Suggested Time Limit: 3 minutes*

Let X equal the unknown quantity.

$$x + 4\frac{1}{2} \text{ lb.} = 2\frac{1}{2} \text{ lb.} + 3\frac{1}{4} \text{ lb.}$$

$$x + 4\frac{1}{2} \text{ lb.} = 5\frac{3}{4} \text{ lb.}$$

$$x = 1\frac{1}{4} \text{ lb.} \text{ or } \frac{5}{4} \text{ lbs.}$$

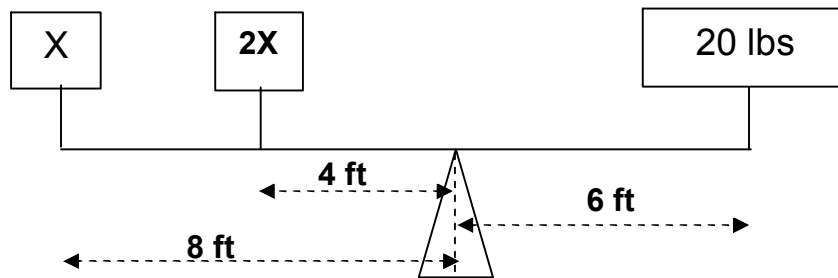

38. What value of **X**, in pounds, will make the lever balance at the fulcrum?
 - *Suggested Time Limit: 3 minutes*

$$8x + 4(2x) = 6(20)$$

$$16x = 120$$

$$x = 7.5 \text{ lbs.}$$

39. In the game of golf, “par” is the term used to describe the number of shots it should take a professional golfer to get the ball in the hole. The table below shows the par scores and Tiger Woods’ scores for the last nine holes of the 2000 PGA Championship. How many shots below par was Tiger Woods in total for the nine holes? - *Suggested Time Limit: 3 minutes*

Hole Number	Par Score	Tiger Woods
10	5	4
11	3	3
12	4	3
13	4	4
14	3	2
15	4	4
16	4	4
17	4	3
18	5	4

$$\text{Par for last 9 holes} = 5 + 3 + 4 + 4 + 3 + 4 + 4 + 4 + 5 = 36$$

$$\text{Tiger Woods score for last 9 holes} = 4 + 3 + 3 + 4 + 2 + 4 + 4 + 3 + 4 = 31$$

Tiger's score is 5 under par.

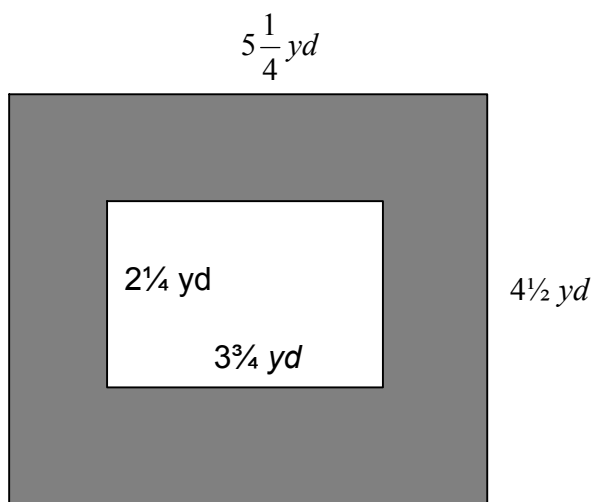

40. Find the shaded area in the above figure. Write your answer as a mixed number or proper fraction in reduced form. - *Suggested Time Limit: 3 minutes*

$$A_{\text{shaded}} = \left(5\frac{1}{4} \times 4\frac{1}{2}\right) \text{ yd.}^2 - \left(3\frac{3}{4} \times 2\frac{1}{4}\right) \text{ yd.}^2$$

$$A_{\text{shaded}} = \left(\frac{21}{4} \times \frac{9}{2}\right) \text{ yd.}^2 - \left(\frac{15}{4} \times \frac{9}{4}\right) \text{ yd.}^2$$

$$A_{\text{shaded}} = \left(\frac{189}{8}\right) \text{ yd.}^2 - \left(\frac{135}{16}\right) \text{ yd.}^2$$

$$A_{\text{shaded}} = \left(\frac{378}{16}\right) \text{ yd.}^2 - \left(\frac{135}{16}\right) \text{ yd.}^2$$

$$A_{\text{shaded}} = \left(\frac{243}{16}\right) \text{ yd.}^2 \text{ or } 15\frac{3}{16} \text{ yd.}^2$$